

**FHS SAE Split flange halves**

ISO 6162-1/-2

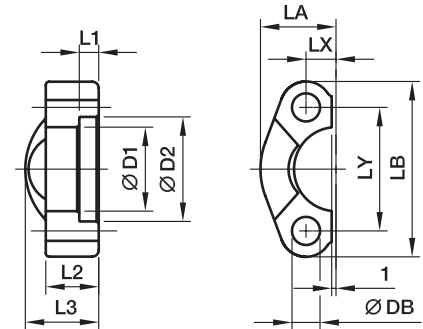

**3000 PSI Series**

Nom. flange size												Bolts		Weight (steel) kg/piece	Order code*	PN (bar) <sup>1)</sup>	
SAE (in.)	ISO (DN)	D1	D2	L1	L2	L3	LA	LB	LX	LY	DB	(metr.)	(unc.)			CF	SS
1/2	13	24.3	31.0	6.2	13	19	23.0	54.0	8.7	38.1	8.9	M 08×25	5/16×1 1/4	0.07	<b>FHS32</b>	345	345
3/4	19	32.2	38.9	6.2	14	22	25.9	65.0	11.1	47.6	10.6	M 10×30	3/8×1 1/4	0.09	<b>FHS33</b>	345	345
1	25	38.5	45.2	7.5	16	24	29.2	69.9	13.1	52.4	10.6	M 10×30	3/8×1 1/4	0.11	<b>FHS34</b>	345	345
1 1/4	32	43.7	51.6	7.5	16	22	36.3	79.4	15.1	58.7	10.6	M 10×35	-	0.17	<b>FHS35/10</b>	276	276
1 1/4	32	43.7	51.6	7.5	16	22	36.3	79.4	15.1	58.7	12.0	-	7/16×1 1/2	0.17	<b>FHS35/12</b>	276	276
1 1/4	32	43.7	51.6	7.5	16	22	36.3	79.4	15.1	58.7	12.5	M 12×35	-	0.17	<b>FHS35</b>	276	276
1 1/2	38	50.8	61.1	7.5	16	25	41.1	93.8	17.9	69.9	13.5	M 12×35	1/2×1 1/2	0.24	<b>FHS36</b>	207	207
1 1/2	38	50.8	61.1	7.5	16	25	41.1	93.8	17.9	69.9	14.5	M 14×35	-	0.24	<b>FHS36/14</b>	207	207
2	51	62.8	72.3	9.0	16	26	48.2	101.6	21.4	77.8	13.5	M 12×35	1/2×1 1/2	0.27	<b>FHS38/12</b>	207	207
2	51	62.8	72.3	9.0	16	26	48.2	101.6	21.4	77.8	14.5	M 14×35	-	0.27	<b>FHS38</b>	207	207
2 1/2	64	74.9	84.9	9.0	19	38	54.1	114.3	25.4	88.9	13.5	M 12×40	1/2×1 3/4	0.45	<b>FHS310</b>	172	172
2 1/2	64	74.9	84.9	9.0	19	38	54.1	114.3	25.4	88.9	14.5	M 14×40	-	0.45	<b>FHS310/14</b>	172	172
3	76	90.9	102.4	9.0	22	41	65.3	135.0	31.0	106.4	16.7	M 16×45	5/8×1 3/4	0.71	<b>FHS312</b>	138	138
3 1/2	89	102.4	115.0	10.7	22	28	68.6	152.4	34.9	120.7	16.7	M 16×45	5/8×2	0.65	<b>FHS314</b>	34	34
4	102	115.1	127.8	10.7	25	35	74.9	162.0	38.9	130.2	16.7	M 16×50	5/8×2	0.87	<b>FHS316</b>	34	34
5	127	140.5	153.2	10.7	28	41	89.4	184.2	46.0	152.4	16.7	M 16×50	5/8×2 1/4	1.25	<b>FHS320</b>	34	34

**6000 PSI Series**

1/2	13	24.6	32.5	7.2	16	22	24.0	56.4	9.1	40.5	9.0	M 08×30	5/16×1 1/4	0.08	<b>FHS62</b>	420	420
3/4	19	32.5	42.0	8.3	19	28	30.0	72.0	11.9	50.8	11.0	M 10×35	3/8×1 1/2	0.18	<b>FHS63</b>	420	420
1	25	38.8	48.4	9.0	24	33	34.8	81.0	13.9	57.2	13.0	M 12×45	-	0.27	<b>FHS64</b>	420	420
1	25	38.9	48.4	9.0	24	33	34.8	81.0	13.9	57.2	12.0	-	7/16×1 3/4	0.27	<b>FHS64/12</b>	420	420
1 1/4	32	44.5	54.8	9.8	27	38	38.6	95.3	15.9	66.6	15.0	M 14×50	-	0.27	<b>FHS65</b>	420	420
1 1/4	32	44.5	54.8	9.8	27	38	38.6	95.3	15.9	66.6	13.0	M 12×45	1/2×1 3/4	0.27	<b>FHS65/12</b>	420	420
1 1/2	38	51.6	64.3	12.1	30	43	47.5	112.8	18.3	79.3	17.0	M 16×55	5/8×2 1/4	0.40	<b>FHS66</b>	420	420
2	51	67.6	80.2	12.1	37	52	56.9	133.4	22.2	96.8	22.0	M 20×65	3/4×2 3/4	0.40	<b>FHS68</b>	420	420
2 1/2	64	90.0	108.0	20.0	45	45	75.1	180.0	29.4	123.8	25.0	M 24×75	-	0.68	<b>FHS610</b>	420	420
3	76	115.0	132.5	25.0	55	55	99.1	215.0	35.7	152.4	31.5	M 30×90	-	1.05	<b>FHS612</b>	420	420

<sup>1)</sup>Pressure shown = Item deliverable

PN (bar) = PN (MPa)  
10

\*Please add the **suffixes** below according to the material/surface required.

Order code suffixes			
Material	Suffix surface and material	Example	Description
Steel, zinc plated, Cr(VI)-free	CF	FHS32CFX	only flange half
Stainless steel	SS	FHS32SSX	only flange half